

# DRENAG 1000-1200

## SUBMERSIBLE PUMPS



### TECHNICAL DATA

**Operating range:** from 3 to 28 m<sup>3</sup>/h with head up to 17 metres.

**Pumped liquid:** rain water, ground water, sandy water from construction sites and clean, non aggressive, waste water.

**Free passage of solids:** 10 mm.

**Liquid temperature range:**

- from 0 °C to +35 °C for domestic use (EN 60335-2-41).

- from 0 °C to +50 °C for other uses.

**Maximum ambient temperature for operation with motor above water:** +40 °C

**Maximum immersion depth:** 7 metres.

**Motor protection class:** IP 68

**Insulation class:** F

**Standard voltage:** 220-240 V - 50Hz single-phase.

380-415 V - 50Hz three-phase.

**Installation:** fixed or portable, vertical or horizontal.

### APPLICATIONS

Stainless steel centrifugal submersible pump with microcast ring impeller, suitable for draining clean waste water, sandy water, muddy water with solid particles of sizes up to 10 mm without fibres. Suitable for residential applications and for construction sites, also in case of unexpected flooding.

### CONSTRUCTION FEATURES OF THE PUMP

Pump body, microcast ring impeller, motor flange, filter and disc, motor casing, cable compartment casing with handle and cover in AISI 304 stainless steel. Insulating rubber covered handle. AISI 316 stainless steel motor shaft. Double mechanical seal with interposed oil chamber (non-toxic oil) in carbon-alumina on the motor side, and silicon carbide-silicon carbide on the pump side.

### CONSTRUCTION FEATURES OF THE MOTOR

Dry, asynchronous and waterproof motor, cooled by the pumped liquid. Rotor running on permanently lubricated sealed ball bearings, selected to ensure low noise and durability. Thermo-ampereometric protection provided as standard. Permanently connected capacitor in the single-phase version.

The single-phase version can be supplied with float for automatic operation. Power cable: 10 metre H07RN-F, with UNEL 47166-68 plug for the single-phase version.

Number of poles: 2

Max starts/hour: 20

## MATERIALS

N.	PARTS*	MATERIALS
1	PUMP BODY	AISI 304 STAINLESS STEEL
4	IMPELLER	X5CrNi 1810 - UNI 6900/71
7	MOTOR SHAFT	MICROCAST STAINLESS STEEL AISI 316 X5CrNiMo 1712 - UNI 6900/71
16	MECHANICAL SEAL	PUMP SIDE
		MOTOR SIDE
36	SEAL COVER	AISI 304 STAINLESS STEEL X5CrNi 1810 - UNI 6900/71
42	STRAINER	
54	MOTOR CASING	
69	PUMP LINER	
92	STRAINER COVER	
120	HANDLE	AISI 304 STAINLESS STEEL X5CrNi 1810 - UNI 6900/71 INSULATING RUBBER COATED

\* In contact with the liquid

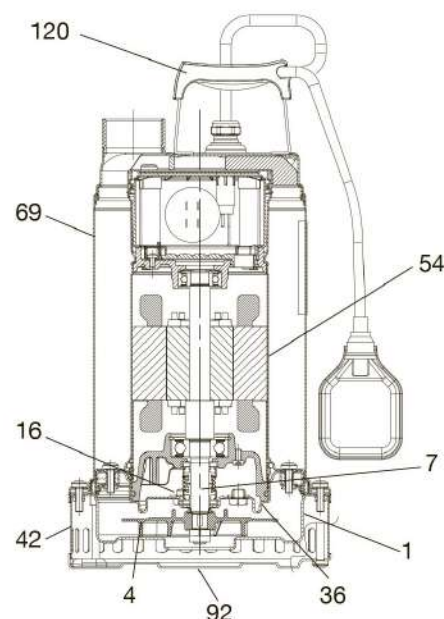

### PERFORMANCE RANGE

The performance curves are based on kinematic viscosity values = 1 mm<sup>2</sup>/s and density equal to 1000 kg/m<sup>3</sup>. Curve tolerance according to ISO 9906.

#### GRAPHIC SELECTION TABLE

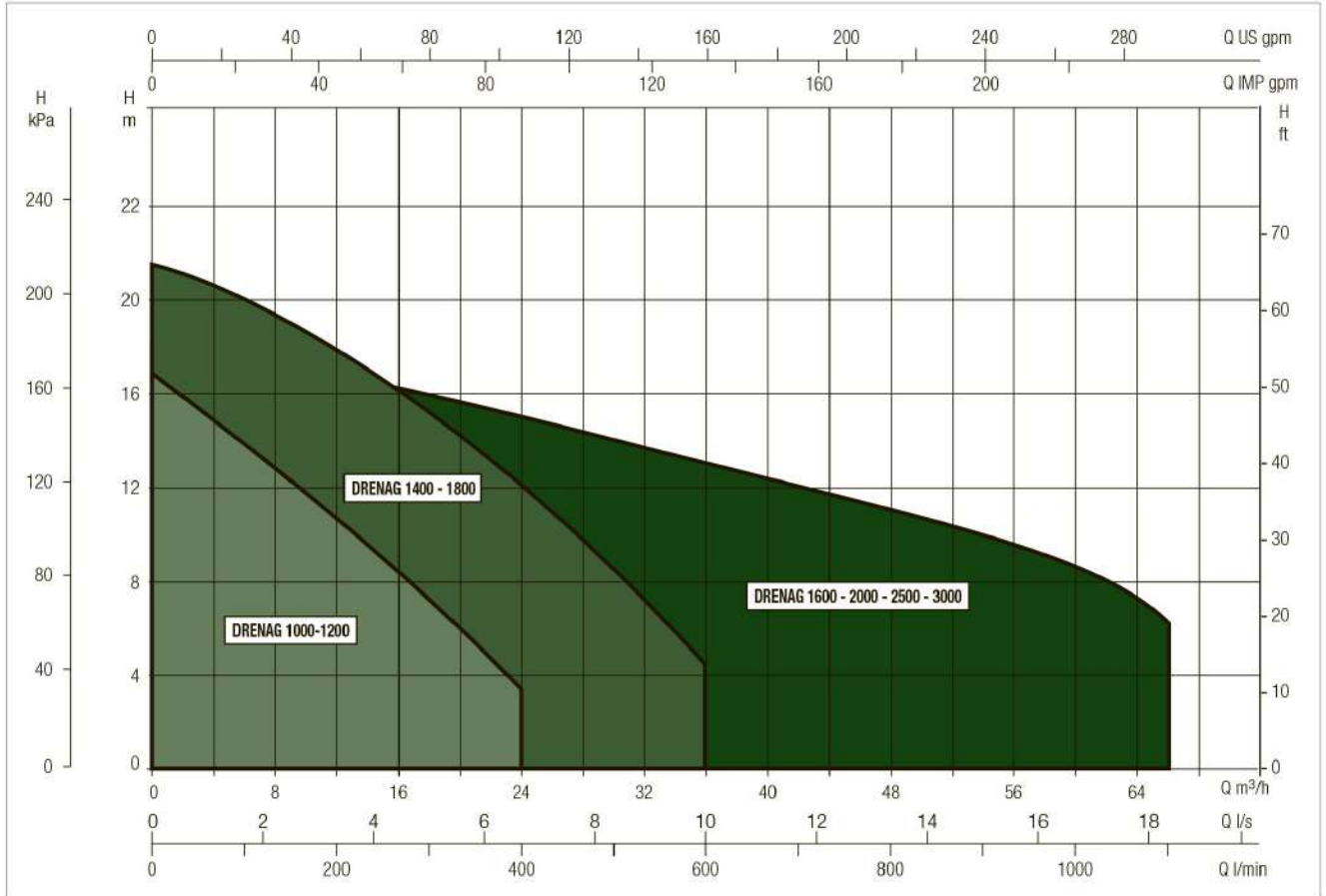

### SELECTION TABLE - DRENAG 1000-1200

MODEL	Q= m <sup>3</sup> /h	0	3	6	9	12	15	18	24	30	36	42	48	54	60	66
	Q=l/min	0	50	100	150	200	250	300	400	500	600	700	800	900	1000	1100
DRENAG 1000 M-T	H (m)	15.3	13.7	12.1	10.5	8.7	6.8	4.7								
DRENAG 1200 M-T		17	15.4	13.8	12.4	10.7	9	7.3	3.3							

# DRENAG 1000 - 1200 - SUBMERSIBLE PUMPS FOR DRAINING CONSTRUCTION SITE CLEAN AND SANDY WATER

Liquid temperature range: from 0 °C to +35 °C for domestic use - from 0 °C to +50 °C for the other uses.

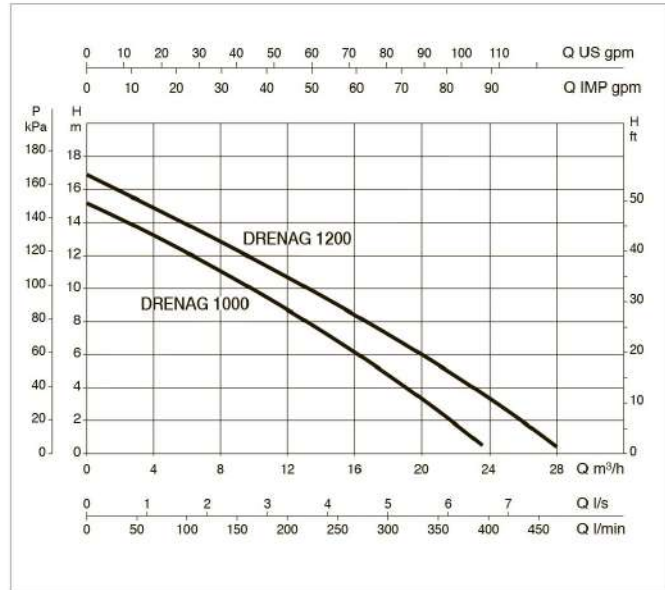
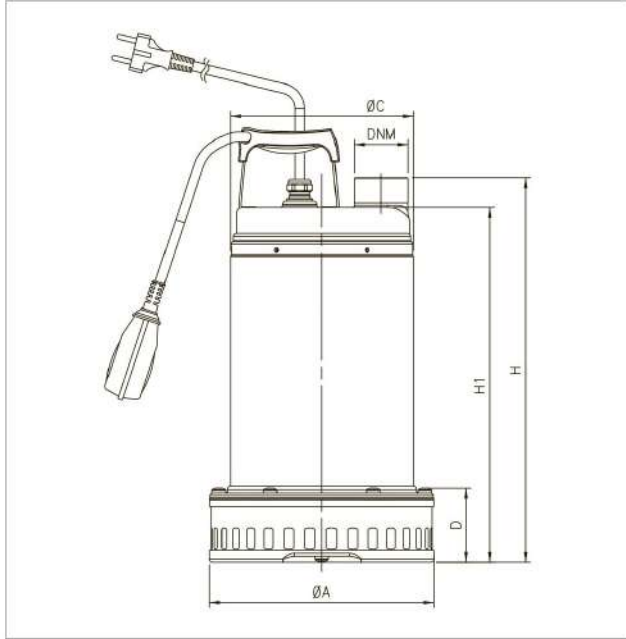

The performance curves are based on kinematic viscosity values = 1 mm²/s and density equal to 1000 kg/m³. Curve tolerance according to ISO 9906.

MODEL	ELECTRICAL DATA						
	POWER INPUT 50 Hz	P1 MAX W	P2 NOMINAL		In A	CAPACITOR	
			kW	HP		µF	Vc
DRENAG 1000 M	1 x 220V -240V ~	1.29	1	1.36	6	25	450
DRENAG 1000 T	3 x 400V ~	1.18	1	1.36	2.43	-	-
DRENAG 1200 M	1 x 220V -240V ~	1.85	1.2	1.6	7.5	30	450
DRENAG 1200 T	3 x 400V ~	1.65	1.2	1.6	3.24	-	-

MODEL	Ø A	Ø C	D	H	H1	Ø DNM	PACKING DIMENSIONS			VOLUME (m³)	WEIGHT kg
							L/A	L/B	H		
DRENAG 1000	215	175	71	413	385	1 ½" F	240	600	250	0.034	17
DRENAG 1200	215	175	71	413	385	1 ½" F	240	600	250	0.034	18.5

## PORTABLE INSTALLATION

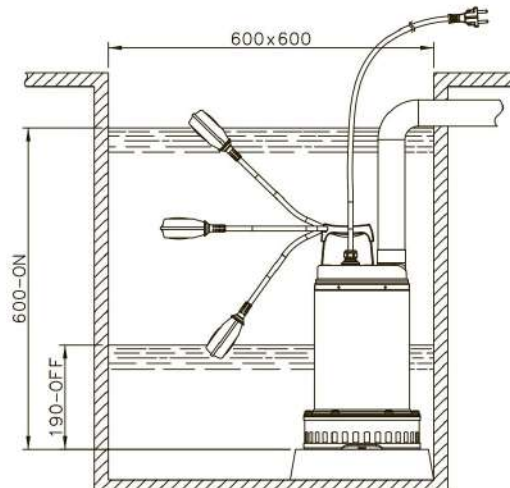

+7 (495) 669 86 99, info@6698699.ru

